



A Portable Actuator for  
Remotely Operating Select ABB Type SACE  
Breakers



**Model SACE-2**

**User's Manual**



*User's Manual  
For Model SACE-2*

- 1.0 Arc-blast Hazards**
- 2.0 Safety Information**
  - 2.1 Finger pinch points
  - 2.2 Strong magnets
- 3.0 Battery Information**
  - 3.0 Battery Requirements
  - 3.1 Battery Life
  - 3.2 Battery Replacement
  - 3.3 Connecting/Disconnecting Batteries
- 4.0 Operation**
  - 4.1 Connecting the control cable
  - 4.2 Sequence of operation
  - 4.3 Actuator Mounting Bracket
  - 4.4 Attaching and Removing the Actuator
  - 4.5 Indicator lights
- 5.0 Care and Storage**
- 6.0 Warranty**
- 7.0 Specifications**

## 1.0 Arc-blast Hazards

The hazards associated with electrical arc-blasts are well documented. Studies conducted by numerous industries and professional organizations have sought to quantify the intensity of arc-blast, the risks to personnel, and various methodologies for mitigating the risks.

Without doubt, increasing the distance between the arc and a human is the single greatest favorable factor in reducing injuries.

The Chicken Switch® is not a panacea but rather one more tool available for protecting workers while they are performing electrical switching.

Using a Chicken Switch® may not negate the need for additional personal protective measures. The user is ultimately responsible for evaluating each situation to determine if additional protective measures are needed.



### **WARNING**

**Electrical switching may present risk of serious injury or death. This device should only be used by qualified persons after careful analysis of the hazards.**

## 2.0 Safety Information

ALWAYS connect the control cable to the actuator BEFORE installing the Chicken Switch®.

### 3.0 Battery Requirements

- Sixteen (8) AA alkaline cells are required. Carefully observe polarity when installing cells.
- Rechargeable batteries are not recommended.

#### 3.1 Battery Life

- A set of fresh alkaline cells should give hundreds of operations.

#### 3.2 Battery Replacement

- ALWAYS turn the hand-held controller power switch OFF before replacing batteries to avoid possible static damage of the electronics!

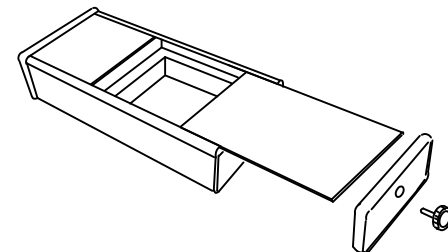

- Turn the control station upside down, remove the endplate retaining knob. Remove the endplate and slide the cover out as shown on previous page.

### 3.3 To connect/disconnect batteries:

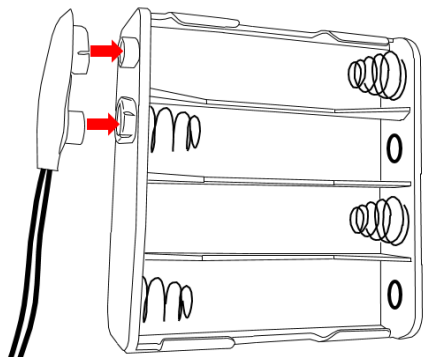

## 4.0 Operation

ALWAYS connect the control cable to the actuator BEFORE installing the Chicken Switch®.

### 4.1 Connecting the control cable:

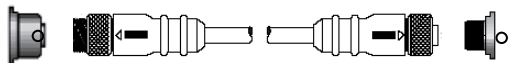

1. Align the arrow on the cable end with the top of the receptacle.
2. Push in and engage the threads on the coupling nut and turn clockwise.
3. After one or two turns of the coupling nut, push in on the cable end. Repeat this until the connector is fully seated.

4. Use a similar technique of turn-stop-and-pull to disengage the cable ends.

### 4.2 Sequence of Operation:

1. The breaker can be charged after installing the actuator.
2. Connect the control cable to the actuator and to the hand-held controller.
3. Attach the actuator on the breaker by completing the steps on the following pages.
4. Ensure you are at a safe distance from the circuit breaker that is to be operated.
5. Turn the Power Switch on top of the hand-held controller to the ON position. The amber LED should illuminate indicating the unit is ready.
6. When ready to operate the actuator, press and HOLD the ENABLE button while depressing either then OFF or ON button for the desired operation. Both buttons must be held depressed until the actuator has fully depressed the button.
7. Release the ENABLE and OFF or ON buttons and the actuator will retract.

### 4.3 Actuator Mounting Bracket

Use of the SACE2 Chicken Switch actuator will require the installation of a mounting bracket on the face of your breaker. These brackets are attached to the breaker using industrial strength double sided adhesive manufactured by 3M. Each breaker that the SACE2 is intended to be used on will require one of these brackets installed. Each SACE2 comes with two mounting brackets. Additional brackets can be purchased from MarTek by calling 1-800-248-4958. Order Part Number P-0209.

Below is a picture of a bracket installed on the breaker. Detailed instructions for installing the bracket will be included with the bracket.



### 4.4 Attaching and Removing the Actuator:

The slot on the bottom of the SACE2 actuator must be aligned over the mounting bracket.

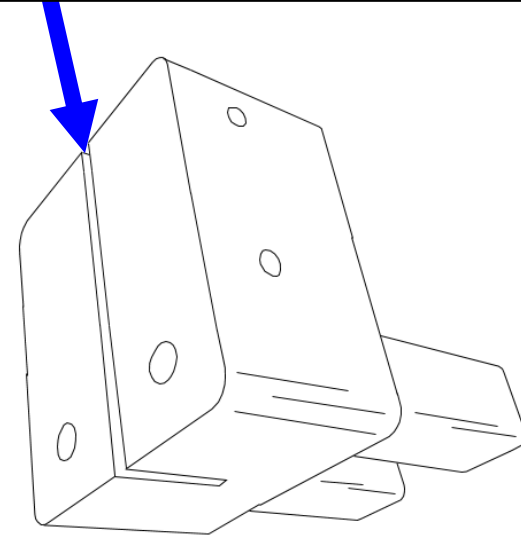

**STEP #1** – Verify that both linear actuators are fully retracted into the actuator base. Note that if the actuators are not fully retracted, you will not be able to install the actuator on the breaker.

**STEP #2** – Align the SACE2 actuator slot over the bracket so that it engages the slots on the bracket.

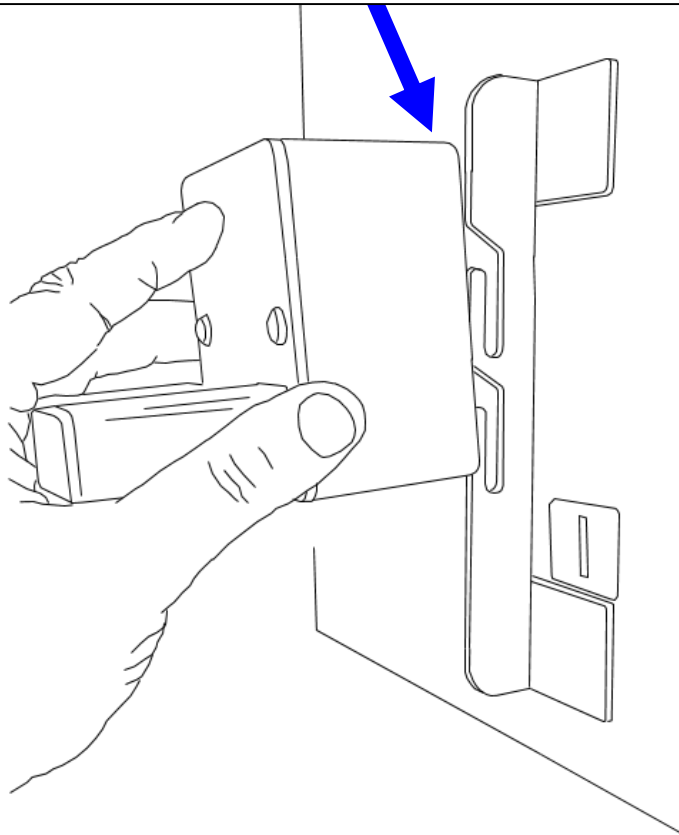

**STEP #3** – The SACE2 actuator should engage the mounting bracket and go flush against the breaker face.

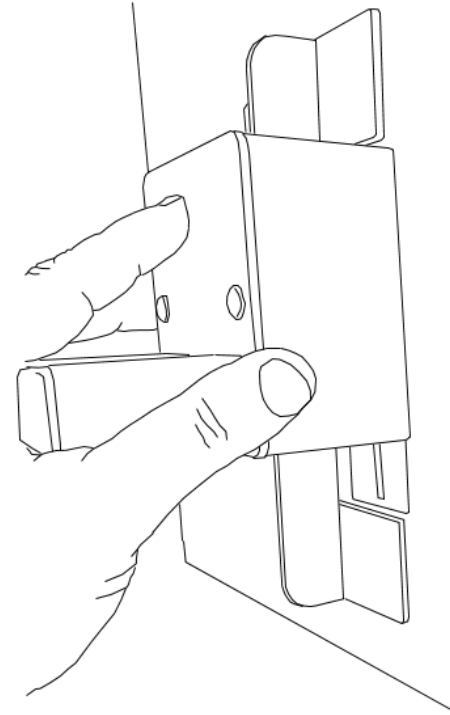

**STEP #4** – Slide the SACE2 actuator downward to lock it into place.

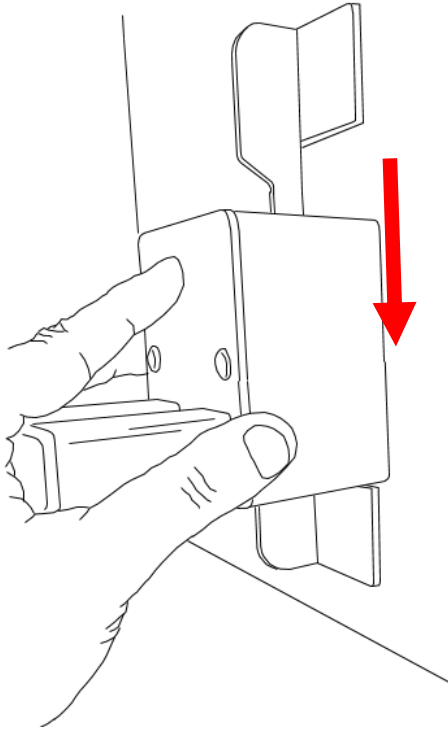

The SACE2 actuator shown in place and ready to use.

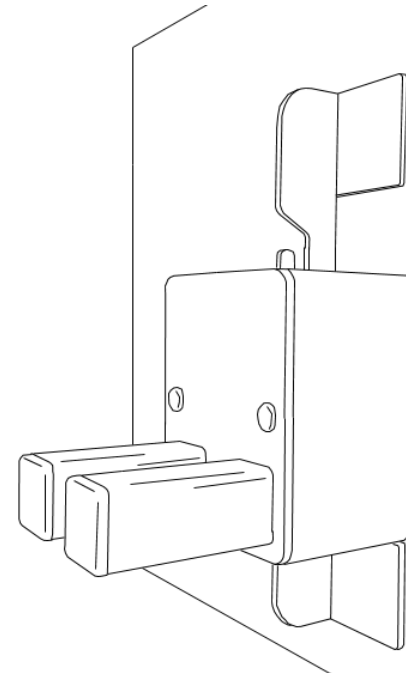

## REMOVING THE ACTUATOR

To remove the actuator, slide the actuator up and remove.

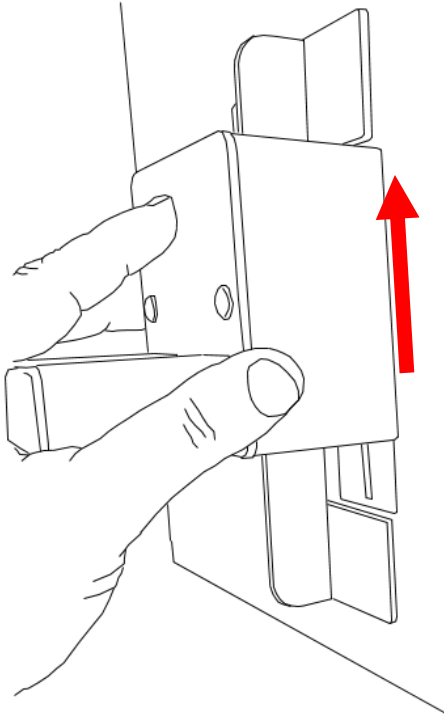

### 4.5 Hand-held Controller

NOTE: Red and Green indicator lights only work when the ENABLE button is depressed.

**GREEN**: indicates the actuator is being commanded to extend the ON actuator.

**RED**: indicates the actuator is being commanded to extend the OFF actuator.

**YELLOW**: indicates the hand-held controller is powered and is ready.

**Rapidly blinking YELLOW** indicates the battery voltage with zero load has fallen to an unacceptable level. Operation is inhibited until batteries with an acceptable voltage level are installed.

#### The ENABLE button:

The Enable button must be continuously depressed in order to command the actuator.

Releasing the enable button has the same effect as releasing either the ON or OFF buttons – both actuators will move to the retracted position.

#### Note:

If either of the actuators are held in the extended position for longer than approximately 2 seconds the actuator will de-energize and will remain in extended position. When the pushbutton or the enable button is released, the actuator will retract.

## 5.0 Care and Storage

Remove all batteries from the control station if the device will not be used for longer than 6 months.

Never store the batteries where the ambient temperature might exceed 110° F.

Avoid getting the unit wet or storing it in a high humidity location.

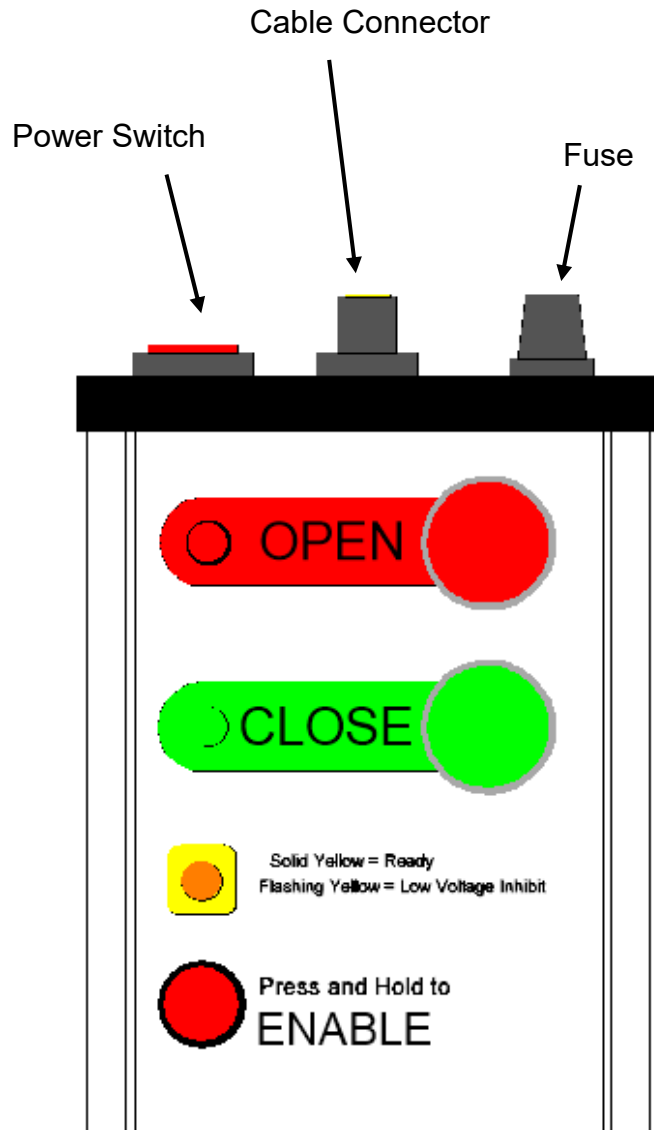



## 6.0 Warranty

MarTek Ltd. guarantees all products manufactured by MarTek Ltd. only against defects in materials and/or workmanship for a period of twelve (12) months commencing on the date the product is received by the customer. THIS WARRANTY IS IN LIEU OF ALL OTHER EXPRESS OR IMPLIED WARRANTIES INCLUDING THOSE OF MERCHANTABILITY AND FITNESS FOR A PARTICULAR PURPOSE.

MarTek Ltd. will, at its option and its cost (excluding shipping expenses), repair, replace or refund the purchase price of any product manufactured by MarTek Ltd. which has a defect in materials and/or workmanship. THIS IS CUSTOMER'S EXCLUSIVE REMEDY FOR BREACH OF WARRANTY. IN NO EVENT WILL MARTEK LTD'S LIABILITY FOR DAMAGES (WHETHER ARISING FROM BREACH OF CONTRACT OR WARRANTY, NEGLIGENCE, STRICT LIABILITY OR OTHERWISE) EXCEED THE PURCHASE PRICE OF THE PRODUCT CONCERNED NOR WILL MARTEK LTD. BE LIABLE FOR PUNITIVE, INCIDENTAL, CONSEQUENTIAL OR SPECIAL DAMAGES (INCLUDING WITHOUT LIMITATION LOST PROFITS) EVEN IF ADVISED OF THE POSSIBILITY OF SUCH DAMAGES.

MarTek Ltd. reserves the right to disallow warranty repairs if the unit has been disassembled or misused, as determined by MarTek Ltd. in good faith. Please contact us at (800)-248-4958 for a return authorization.

### **MarTek Ltd.**

4782 Chimney Drive  
Charleston, WV 25302  
1-304-965-9220  
1-800-248-4958

## 7.0

### **Specifications**

#### **MECHANICAL**

Projected life: 20,000 operations

#### **ELECTRICAL**

Operating voltage: 12 volts DC

Fuse: 3 amp

Power supply: 8 AA alkaline disposable batteries. When used properly, one set of batteries should yield hundreds of operations.

Control Cable: 30 feet in length (9.1 meters), 5-conductor, extra-flexible, PUR insulation

Controller: Requires two-hand operation. The 'enable' button must be depressed while depressing the ON or OFF buttons.

A programmable micro-controller manages control inputs, linear actuators, and performs timing functions to protect the actuator in a stalled condition. Intelligent 'H-bridge' motor drivers provide start/stop/braking actuator functions

# **MarTek Ltd.**

**4782 Chimney Drive  
Charleston, WV 25302**

**1-800-248-4958**

**[www.chickenswitch.com](http://www.chickenswitch.com)**

Chicken Switch is a Registered Trademark of MarTek Ltd.

US Patent 7,623,011 and others Pending

Copyright 2004-2016, MarTek Ltd. All rights reserved.